

www.chirenti.it

**GLASSROOM
&
PARKCAR
LOWCOST
PER
CONCESSIONARIE
&
AUTOSALONI**

Fa.Ro Global Group Srl

Sedel Legale: Viale Salvo d'Acquisto, 11 - 84133 Salerno (SA)

C.F. e P.I. 06099390657 - Rea N° SA497062 - SDI: KRRH6B9

amministrazione@faroglobalgroup.it - 379 179 0796 - 379 172 0280

www.faroglobalgroup.it - www.fullserviceandlifeguard.it - www.manifatturesp.it

www.faroecommerce.it

 **CHIRENTI.IT**
Vetrare Panoramiche 1970





COPERTURE
MODULARI
PER GRANDI
SPAZI



GAZEBO IN
ACCIAIO
CON
COPERTURA
A CUPOLA

GAZEBO IN
ACCIAIO
CON
COPERTURA
A CONO



PARKING
SYSTEM
CON
STRUTTURA
IN ACCIAIO
E
COPERTURA
IN PVC





GRANDE COPERTURA MODULARE A CONI

SISTEMA PAGODA



GAZEBO IN ACCIAIO CON COPERTURA A CUPOLA



GAZEBO IN ACCIAIO CON COPERTURA A CUPOLA





GLASSROOM
ESPOSITIVO
CHIUSO CON
VETRATE



GLASSROOM
ESPOSITIVO
CHIUSO CON
VETRATE

GLASSROOM
ESPOSITIVO
CHIUSO CON
VETRATE



GAZEBO IN
ACCIAIO
CON
COPERTURA
A CUPOLA
CON
VETRATE





GAZEBO IN ACCIAIO CON COPERTURA A CUPOLA



VERANDA ESPOSITIVA PROTETTA CON VETRATE



GRANDI COPERTURE PER AUTO



GAZEBO IN ACCIAIO CON COPERTURA A CUPOLA



COPERTURE CON VETRATE

PER AUTOSALONI E CONCESSIONARIE

Ogni anno, **Concessionarie e Autoparchi** subiscono **danni per milioni di Euro**, causati da violenti grandinate e dannosi raggi solari

***PROTEGGI IL TUO "CAPITALE"**
con EURO 1,10
AL GIORNO (PER AUTO)

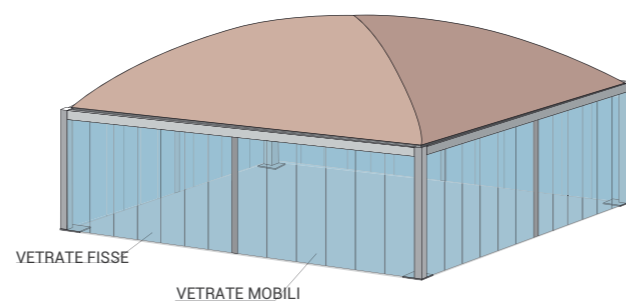
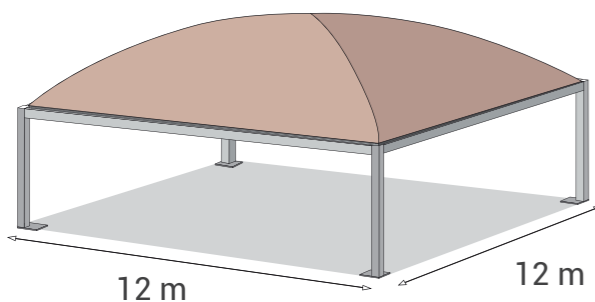

***Ammortamento medio in 5 anni con le agevolazioni fiscali di un LEASING**



- STRUTTURA IN ACCIAIO ZINCATO
- BULLONERIA CON TRATTAMENTO GEOMET
- TELO DI COPERTURA IN PVC IGNIFUGO
- H SOTTO TRAVE STANDARD: fino a cm 280

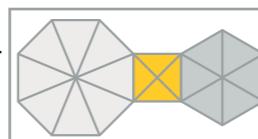

I costi delle strutture aventi forme o misure differenti da quelle indicate nei prospetti saranno sottoposti a preventivo.

COMPOSIZIONI MODULARI

Modello CUPOLA 2

Questo sistema modulare può essere ampliato a piacimento. E' predisposto per essere chiuso lateralmente con vetrate panoramiche scorrevoli e/o fisse.

Dimensioni massime (del singolo modulo)

Modello CUPOLA 1: mt 7 x 7
Modello CUPOLA 2: mt 12 x 12

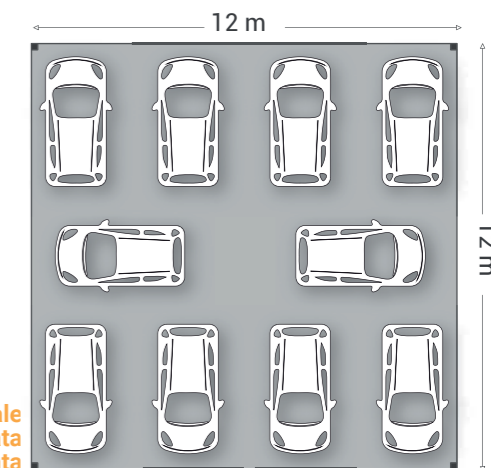

Esempio Modulo A: copertura ottimale per 10 auto di grossa cilindrata o 13 auto di media/piccola cilindrata

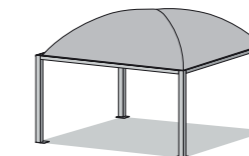
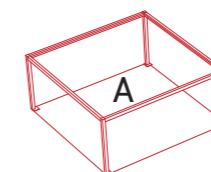
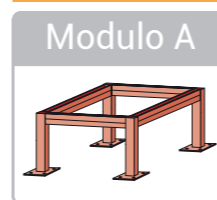

Modulo A
(10/13 auto)

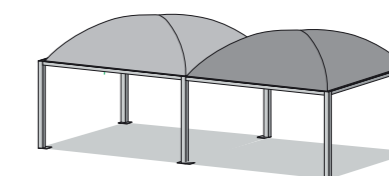
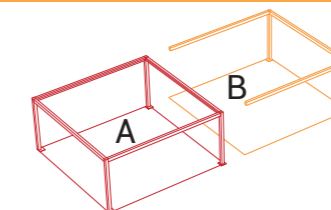
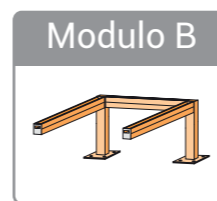

Modulo A+B
(20/26 auto)

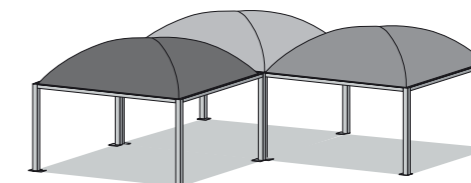
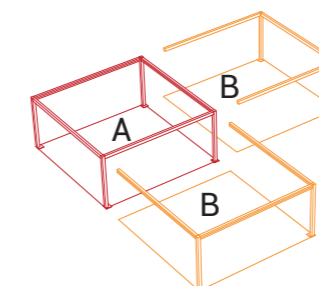
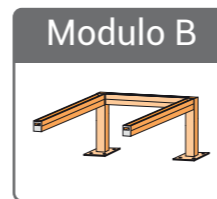

Modulo A+B+B
(30/39 auto)

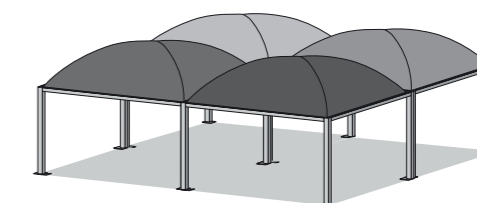
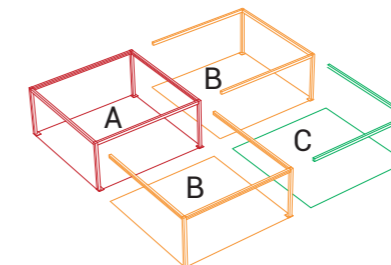
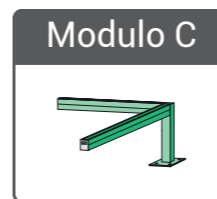

Modulo A+B+B+C
(30/39 auto)

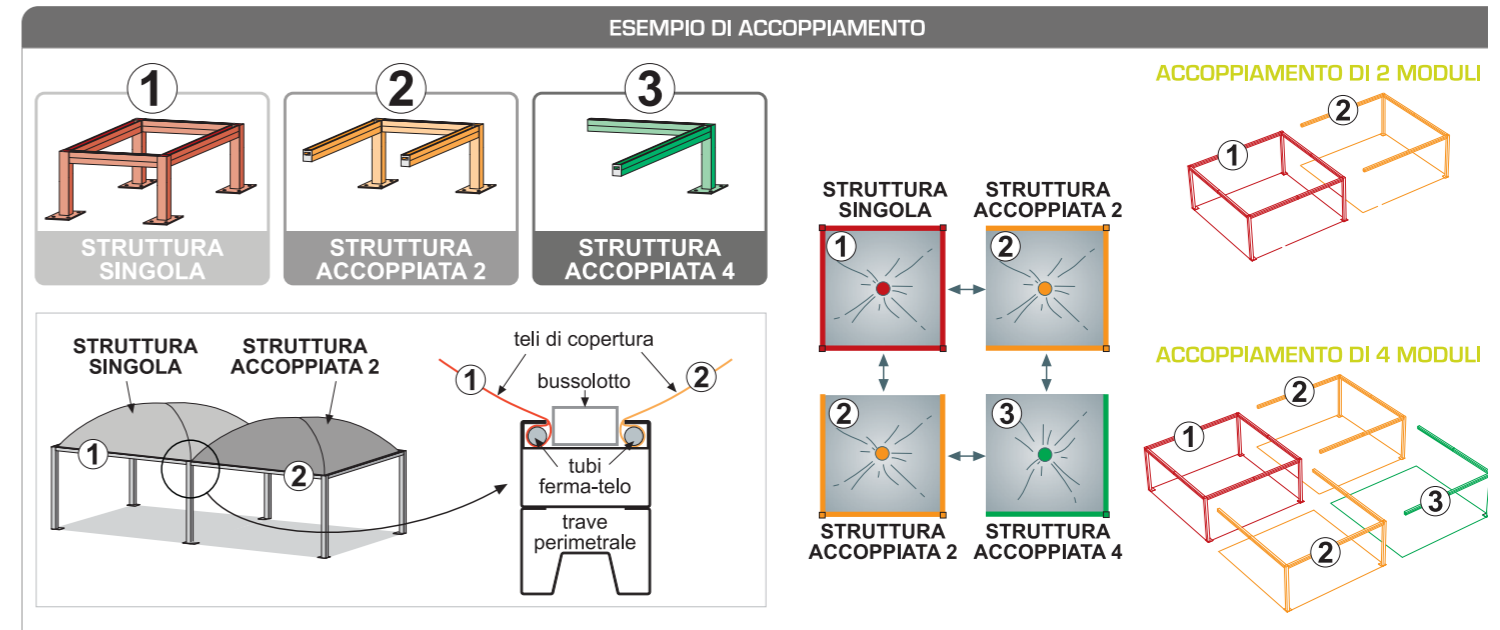
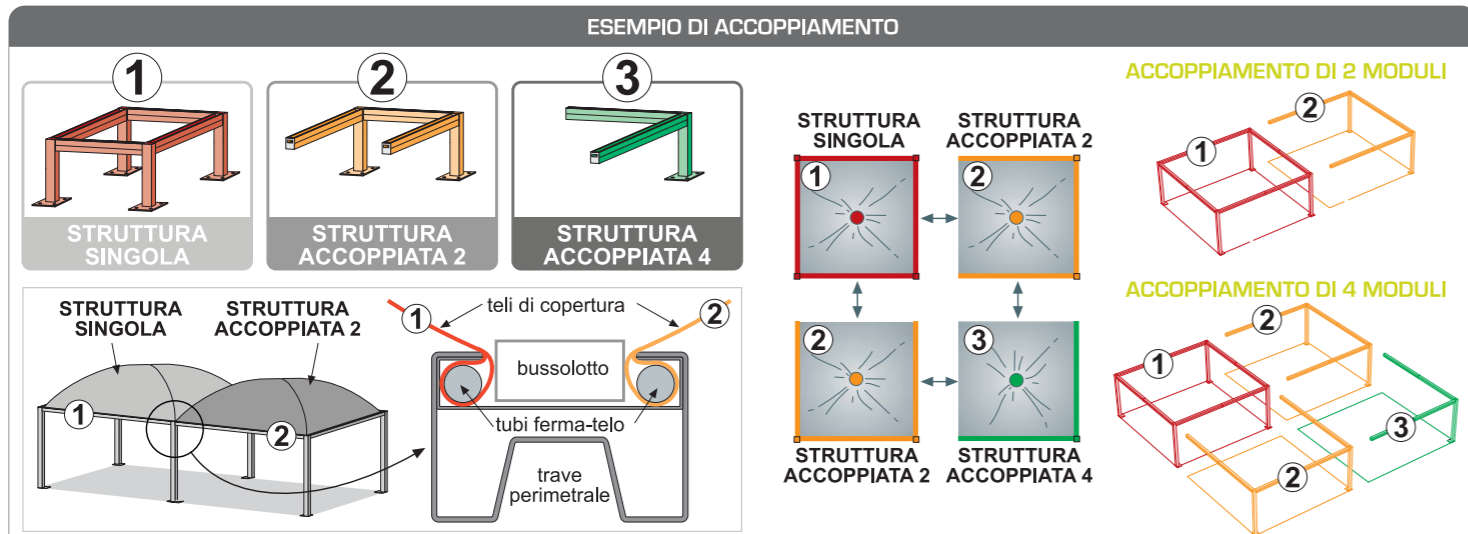
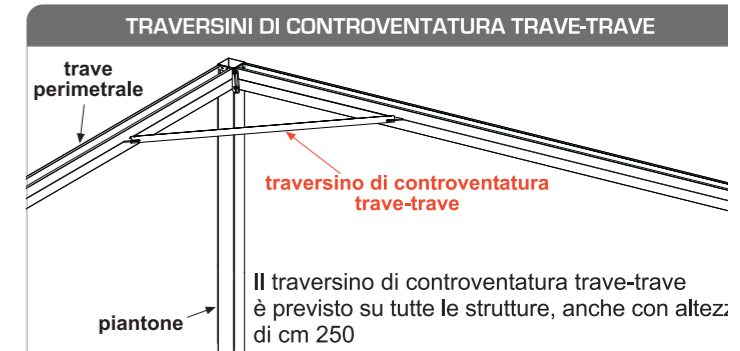
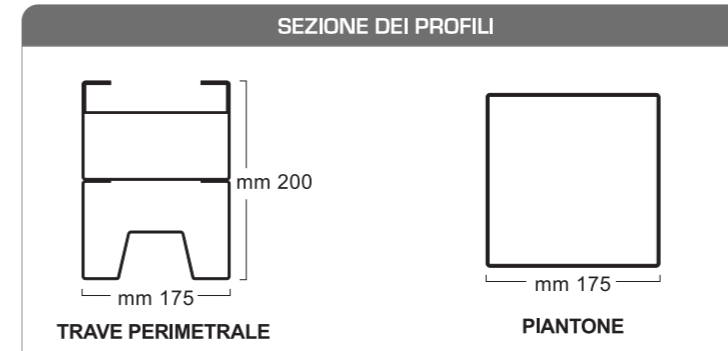
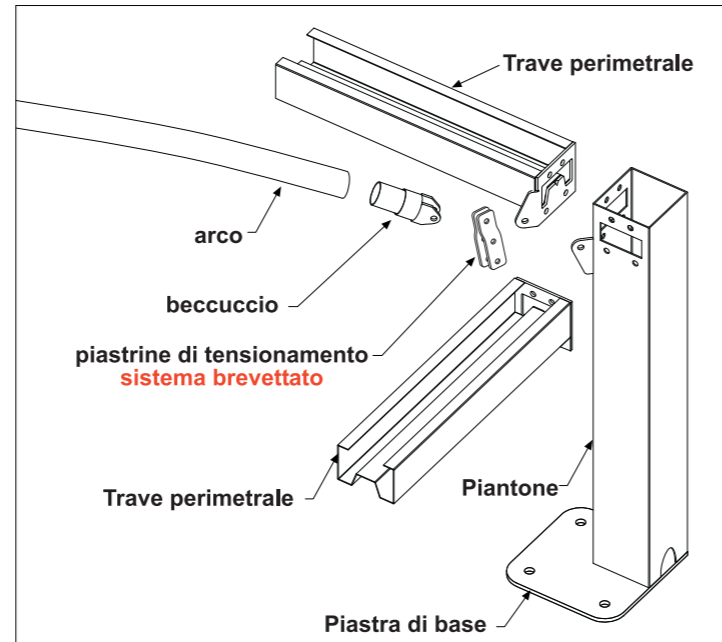
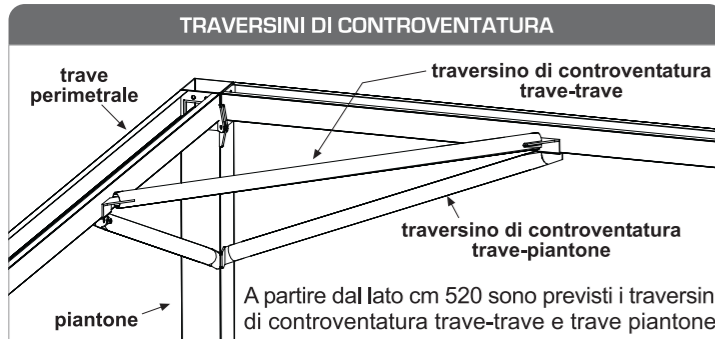
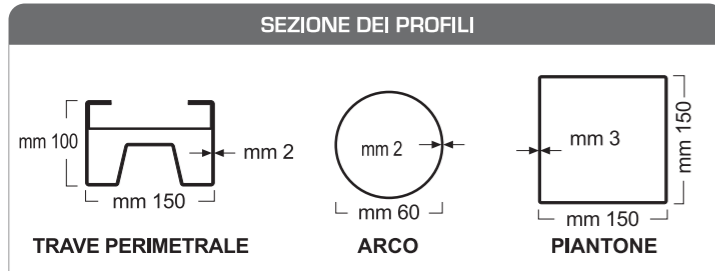

CUPOLA 1 (struttura singola)

Dimensione lato	A ingombro massimo	B interno piantoni	H sotto trave	H2 da sotto trave	Lunghezza Massima	≅ m³	≅ kg	n. colli
cm 400 x 400	400	370	250	87	370	1,20	400	3
cm 500 x 500	500	470	250	125	470	1,20	455	3
cm 600 x 600	600	570	250	140	570	1,20	510	3
cm 700 x 700	700	670	250	150	670	1,20	550	3
cm 750 x 550	750	720	250	148	720	1,20	490	3

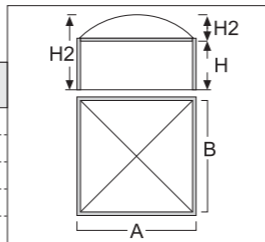

CUPOLA 2 (struttura singola)

Dimensione lato	A ingombro massimo	B interno piantoni	m²	H sotto trave	H2 da sotto trave	H3
cm 700x700	700	665	49	250	165	415
cm 800x800	800	765	64	250	170	420
cm 900x900	900	865	81	250	175	425
cm 1000x1000	1000	965	100	250	180	430
cm 1100x1100	1100	1065	121	250	190	440
cm 1200x1200	1200	1165	144	250	200	450

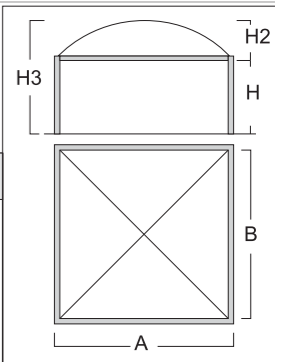



CHIRENTI.IT
Vetratale Panoramiche 1970